



# INSTRUCTION BULLETIN

No. 9018437  
Machine: M17/T17  
Published: 10-2021  
Rev. 01

**NOTE: DO NOT DISCARD the Parts List from the Instruction Bulletin. Place the Parts List in the appropriate place in the machine manual for future reference. Retaining the Parts List will make it easier to reorder individual parts and will save the cost of ordering an entire kit.**

*NOTE: Numbers in parenthesis ( ) are reference numbers for parts listed in Bill of Materials.*

Installation instructions for **kit number 9018436**

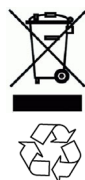
Kit installation must be performed by TennantTrue<sup>®</sup> service or an authorized service provider.

## SYNOPSIS:

This kit contains the parts needed to replace the power steering assembly on M17 sweeper- scrubbers (NA 000000- 012477) (EU U00000- U00725) T17 scrubbers (equipped with power steering) (NA 011000- 014650) and (EU U00400- U01607) that have not been converted to the updated power steering. T17 scrubbers serial numbers (NA 000000- 010999) (EU U00000- U00399) cannot have this kit installed due to a different power steering motor used on the machines in that serial number range. Please follow step-by-step instructions.

## SPECIAL TOOLS / CONSIDERATIONS: NONE

(Estimated time to complete: 4 hours)



### PROTECT THE ENVIRONMENT

Please dispose of packaging materials, used machine components such as batteries and fluids in an environmentally safe way according to local waste disposal regulations.

Always remember to recycle.

## PREPARATION:

1. Remove the access panel from the machine. Set the access panel and all hardware aside. (Fig. 1)



FIG. 1

2. Turn the steering wheel so the master link/ master link lock on the steering chain are easy to see/access and mark the master link.

*NOTE: Locating/marketing the location of master link will make it easier to locate and remove the master link/master link lock from the steering chain later in this procedure if the master link should end up in an area on the steering mechanism where it is difficult to see/access.*

3. Turn on the machine, drive the machine so the drive wheel (front wheel) is oriented straight out from the front of the machine, turn off the machine, set the parking brake, and remove the key. (Fig. 2)



FIG. 2

**FOR SAFETY:** Before leaving or servicing machine, stop on level surface, turn off machine, and remove key.

4. Disconnect the battery cable from the machine.

**WARNING:** Always disconnect battery cables from machine before working on electrical components.

## INSTALLATION:

1. Remove the hardware securing the left control panel to the machine and carefully lift the left control panel from the steering shroud. Do not brake any wire/cable connection when lift the left control panel from the steering shroud. Set all mounting hardware aside. (Fig.3)



FIG. 3

2. Remove the SEMS M8 hex screw (steering tension) from the steering support channel and bearing support plate. Set the SEMS M8 hex screw aside. (Fig. 4/Fig.6)

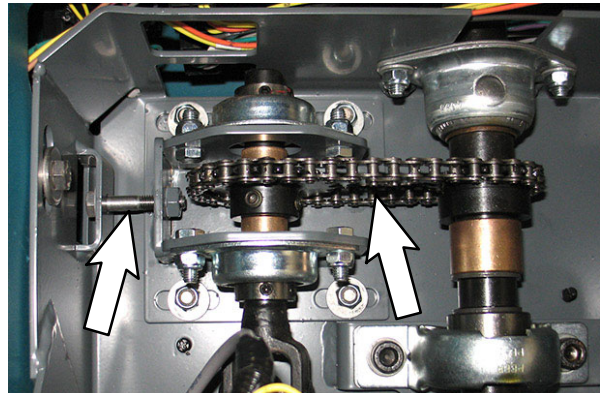
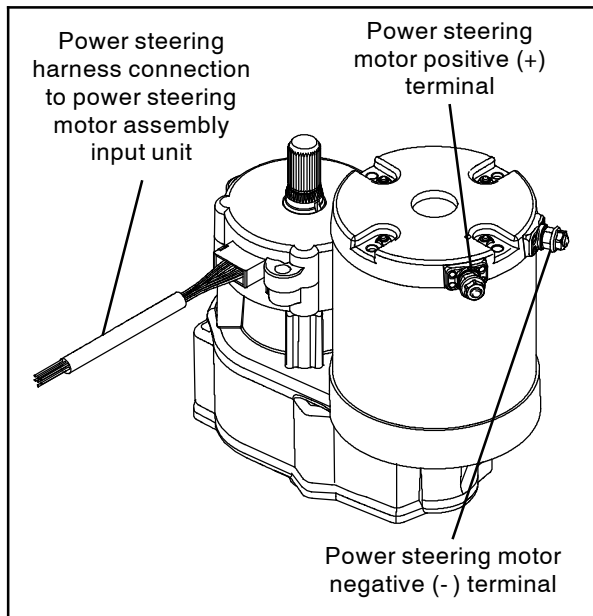


FIG. 4

3. Remove the steering chain from the power steering assembly. Discard the chain link and steering chain. (Fig. 4/Fig.6)

4. Remove the hardware securing the upper power steering shaft to the power steering motor assembly. Discard all removed hardware. (Fig. 6)
5. Remove the hardware securing the steering bearing bracket to the steering support channel. Discard all removed hardware. (Fig. 6)
6. Remove the hardware securing the bearing support plate to the steering support channel. Discard all removed hardware. (Fig. 6)
7. Remove the now loose portion of the power steering assembly from inside the steering support channel. Discard this portion of the power steering assembly. (Fig. 6)
8. Remove the hardware securing the lower power steering shaft to the power steering motor assembly. Set the removed hardware aside. (Fig. 6)
9. Disconnect the power steering harness from the power steering motor assembly input unit and the motor assembly motor positive (+) terminal. (Fig. 5/Fig. 6)
10. Remove the hardware securing the motor support bracket/power steering motor assembly to the steering support channel. Set the removed hardware aside. (Fig. 6)
11. Pull the motor support bracket/power steering motor from the steering support channel and disconnect the main wire harness from the power steering motor assembly motor negative (-) terminal. (Fig. 5/Fig. 6)
12. Remove the power steering motor from the motor support bracket. Set the motor support bracket and hardware aside. Discard the power steering motor assembly hardware. (Fig. 6)
13. Disconnect the power steering harness from the steering controller. (Fig. 6)
14. Remove the steering controller from the steering support channel. Discard the steering controller and hardware. (Fig. 6)



**FIG. 5**

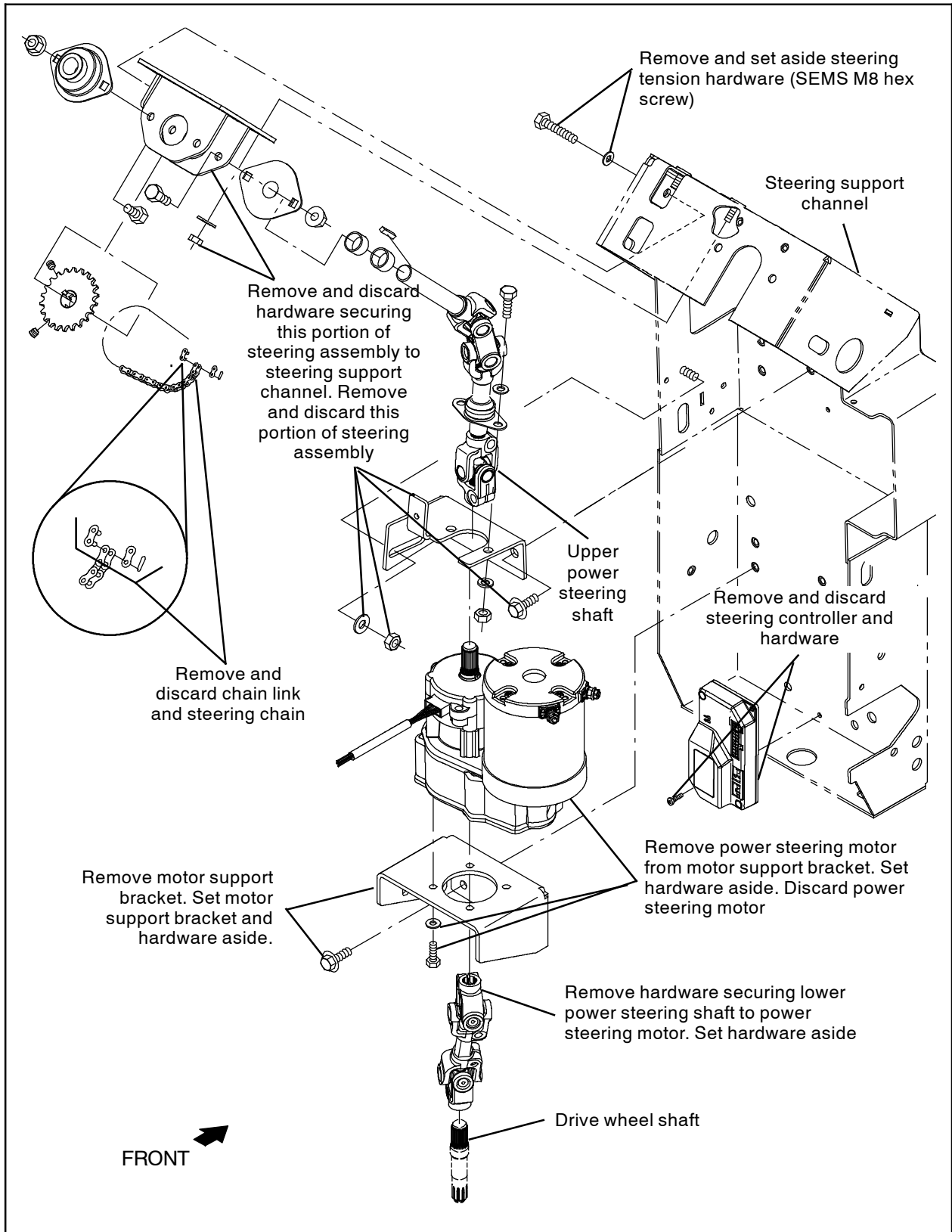
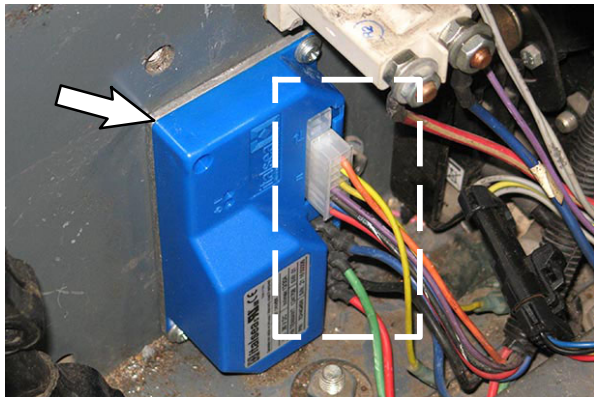


FIG. 6

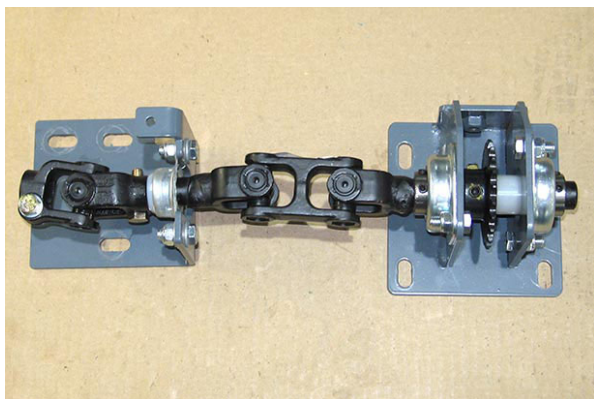
15. Use two M4 pan screws (19) to install the new steering controller (22) onto the steering support channel. (Fig. 7)



**FIG. 7**

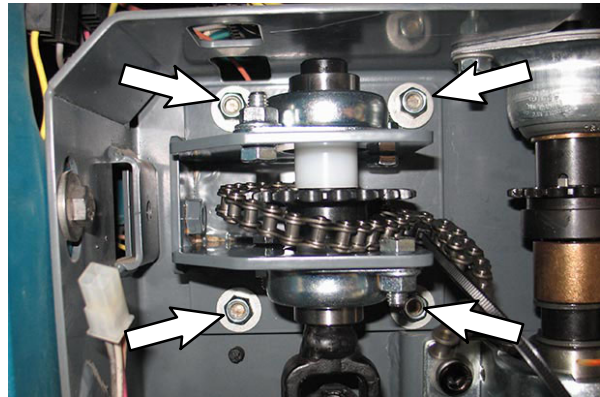
16. Connect the power steering harness to the steering controller (22). (Fig. 7)

*NOTE: Completed power steering shaft assembly (Fig. 8).*



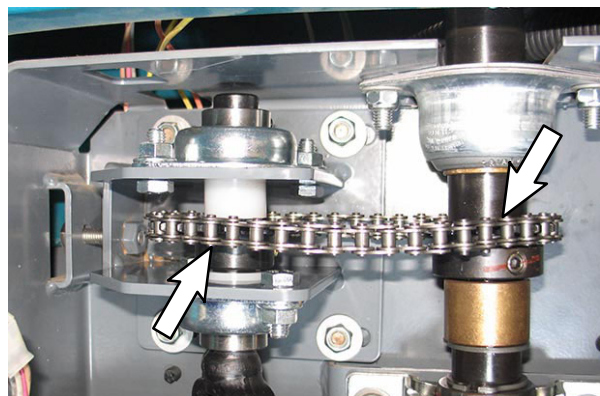
**FIG. 8**

17. Use four M8 hex nuts (13), and four flat washers (12) to install the steering bearing mount bracket (1) onto the steering support channel. Do not completely tighten hardware. Hardware is tightened during later adjustment. (Fig. 9)



**FIG. 9**

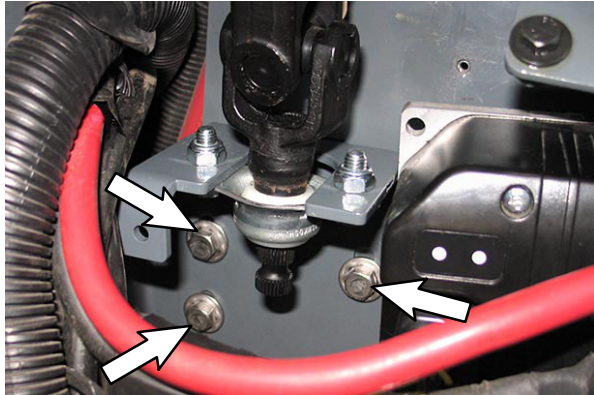
18. Stretch the chain (15) from the sprocket (7) on the steering bearing mount assembly (1) and over to and around the sprocket located on the steering column tube and use the chain link (16) to secure the chain onto the two sprockets. (Fig. 10)



**FIG. 10**



19. Use three SEMS M8 hex screws (14) to install the steering shaft bearing bracket assembly onto the steering support channel. Do not completely tighten hardware. Hardware is tightened during later adjustment. (Fig. 11)



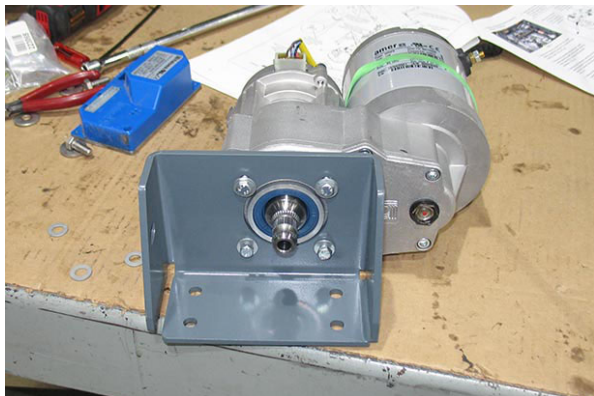
**FIG. 11**

20. Thread the saved M8 hex screw into the steering support channel. (Fig. 12)



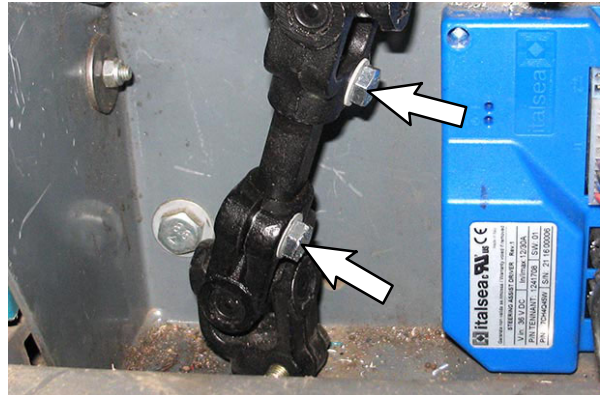
**FIG. 12**

21. Use the saved M6 hex screws and flat washers to install the new power steering motor (18) onto the motor support bracket. (Fig. 13)



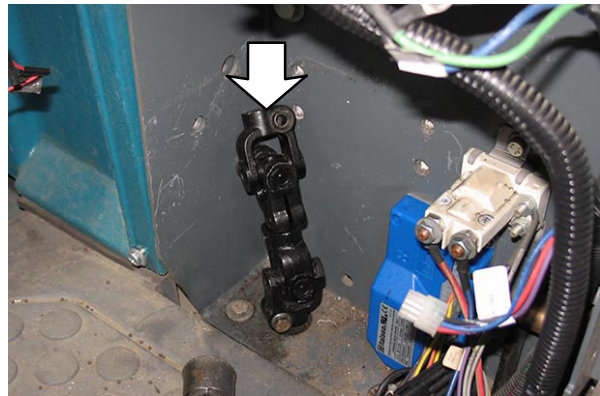
**FIG. 13**

22. Remove the two M8 hex screws from the lower power steering shaft. Set the M8 hex screws aside. (Fig. 14)



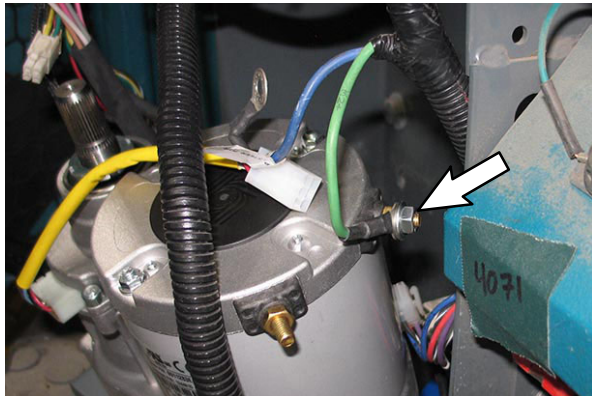
**FIG. 14**

23. Tap the lower power steering shaft down enough to install the power steering motor assembly (18) into the steering support channel and install the lower power steering shaft onto the power steering motor assembly. (Fig. 15)

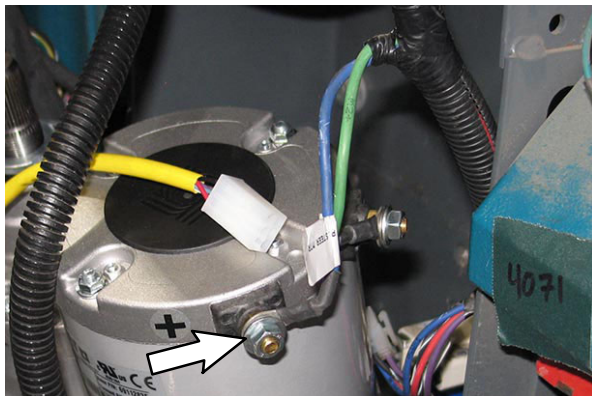


**FIG. 15**

24. Connect the power steering harness green wire to the power steering motor (18) negative (-) terminal and the blue wire to the power steering positive (+) terminal. (Fig. 16/ Fig. 17)

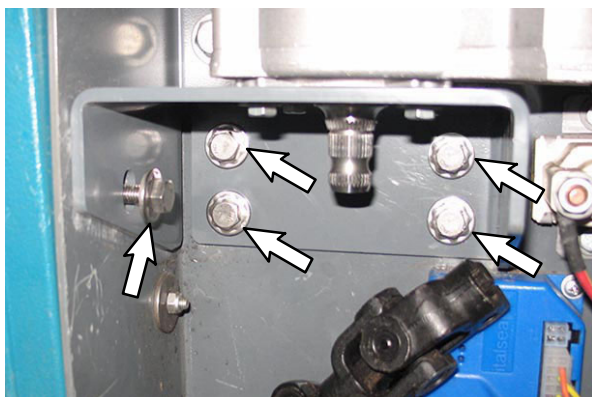


**FIG. 16**



**FIG. 17**

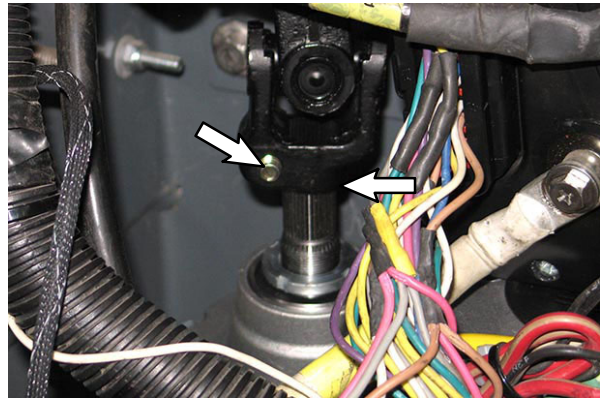
25. Use the five saved SEMS M8 hex screws to install the power steering motor (18) onto the steering support channel. Torque the SEMS M8 hex screws to 22 Nm (16 ft lbs). (Fig. 18)



**FIG. 18**

26. Connect the power steering harness to the power steering motor (18).

27. Install bottom of the power steering top shaft to the power steering motor. (Fig. 19)



**FIG. 19**

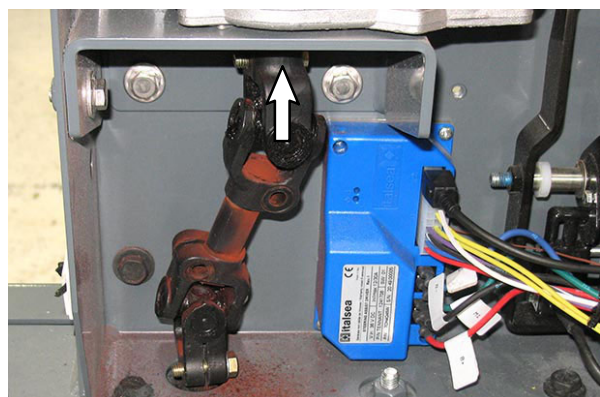
28. Tighten hardware to secure the power steering motor into the bottom of the power steering top shaft. Torque the SEMS M8 hex screws to 22 Nm (16 ft lbs). (Fig. 19)

29. Orient the steering wheel so it is positioned correctly on the machine. (Fig. 20)



**FIG. 20**

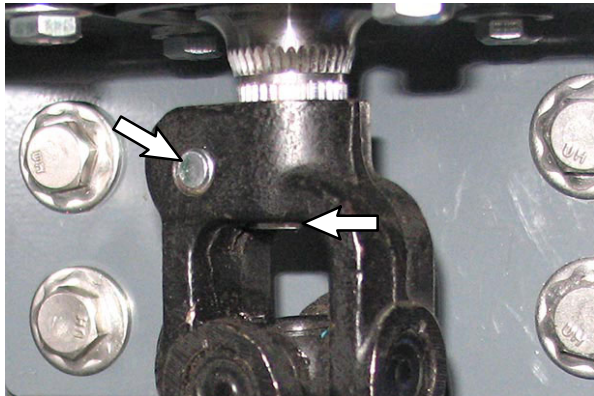
30. Install the lower power steering shaft onto the bottom power steering motor shaft (18). (Fig. 21)



**FIG. 21**

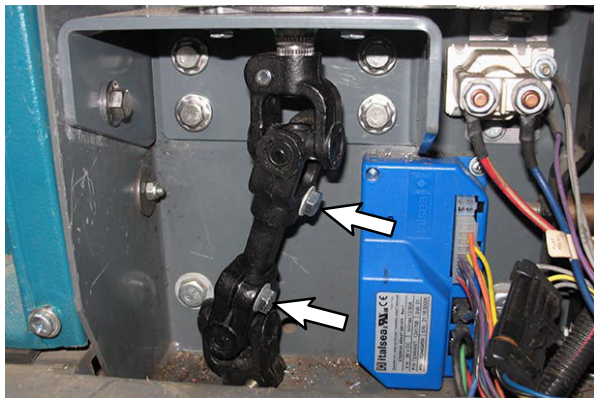


31. Tap up on the lower power steering shaft up until the power steering motor (18) shaft is flush with the surface on the lower power steering shaft as shown. (Fig. 22)



**FIG. 22**

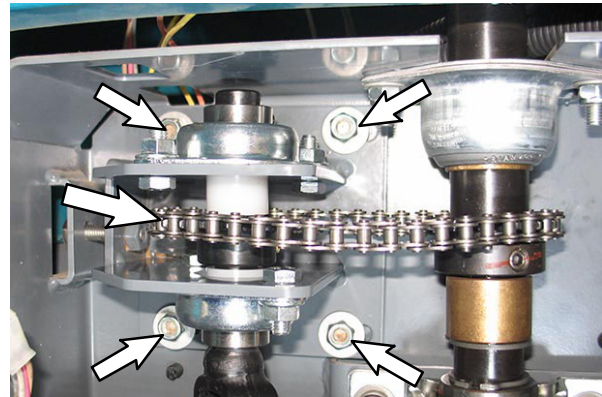
32. Tighten hardware to secure the lower power steering shaft onto the power steering motor (18) shaft. Torque the SEMS M8 hex screws to 22 Nm (16 ft lbs). (Fig. 22)
33. Reinstall the two previously removed M8 hex screws into the lower power steering shaft. Torque the SEMS M8 hex screws to 22 Nm (16 ft lbs). (Fig. 23)



**FIG. 23**

34. Tighten all remaining loose hardware to fully secure all power steering assembly components onto the steering support channel. Torque all SEMS M8 hex screws to 22 Nm (16 ft lbs).

35. Check the steering chain (15) tension. Turn the steering wheel in the complete range of motion to both the left and right. The steering chain should move on the sprockets without the chain becoming too tight or loose. (Fig. 24)



**FIG. 24**

- Loosen the four M8 hex nuts (13) securing the steering bearing mount bracket (1) to the steering support channel and tighten/loosen the M8 hex screw in the steering support channel/steering bearing mount bracket (1) as necessary to adjust the steering chain (15) tension. (Fig. 24/Fig. 25)



**FIG. 25**

- Retighten the four M8 hex nuts (13) securing the steering bearing mount bracket (1) to the steering support channel (Fig. 24)
36. Recheck the steering chain (15) tension. Repeat previous step as necessary until steering chain is at correct tension.
37. Reinstall the left control panel onto the machine.



38. **Calibration:** Connect power steering wire harness YEL- 1 wire and YEL- 2 wire located near the controller (22) to the switch (21). (Fig. 26/Fig. 27/Fig. 29)

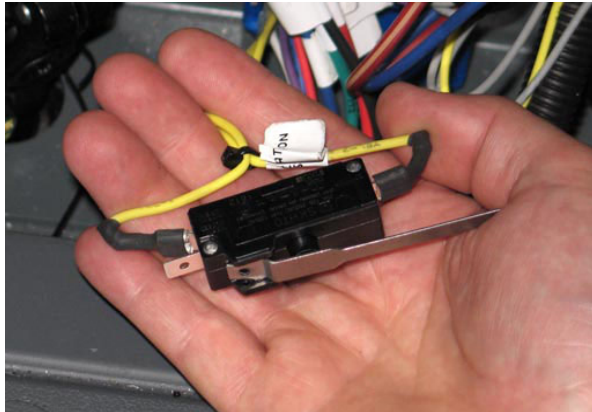


FIG. 26

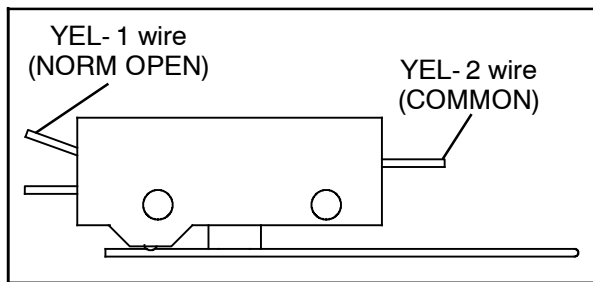


FIG. 27

39. Reconnect the battery cable to the machine.

40. **Calibration:** Turn the key to the ON position.

41. **Calibration:** Turn OFF all machine functions and options. All functions / options (spray nozzle, lights, etc...) must be OFF when the power steering motor (18) is calibrated. The power steering motor will not calibrate if functions/options are on.

42. **Calibration:** Quickly squeeze/activate the switch (21) lever four times within 3 seconds. The power steering controller LED will illuminate each time the snap switch lever is squeezed. The LED will remain illuminated for 2 seconds the fourth time the snap switch lever is squeezed to show the sequence is completed. (Fig. 28)

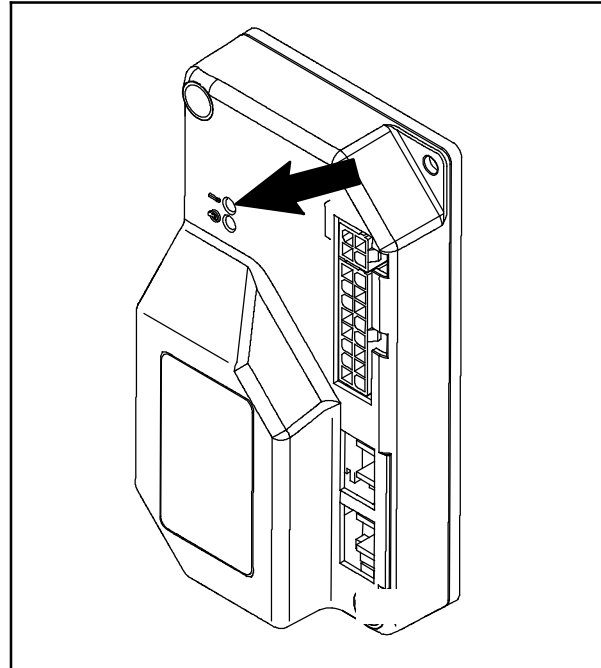


FIG. 28

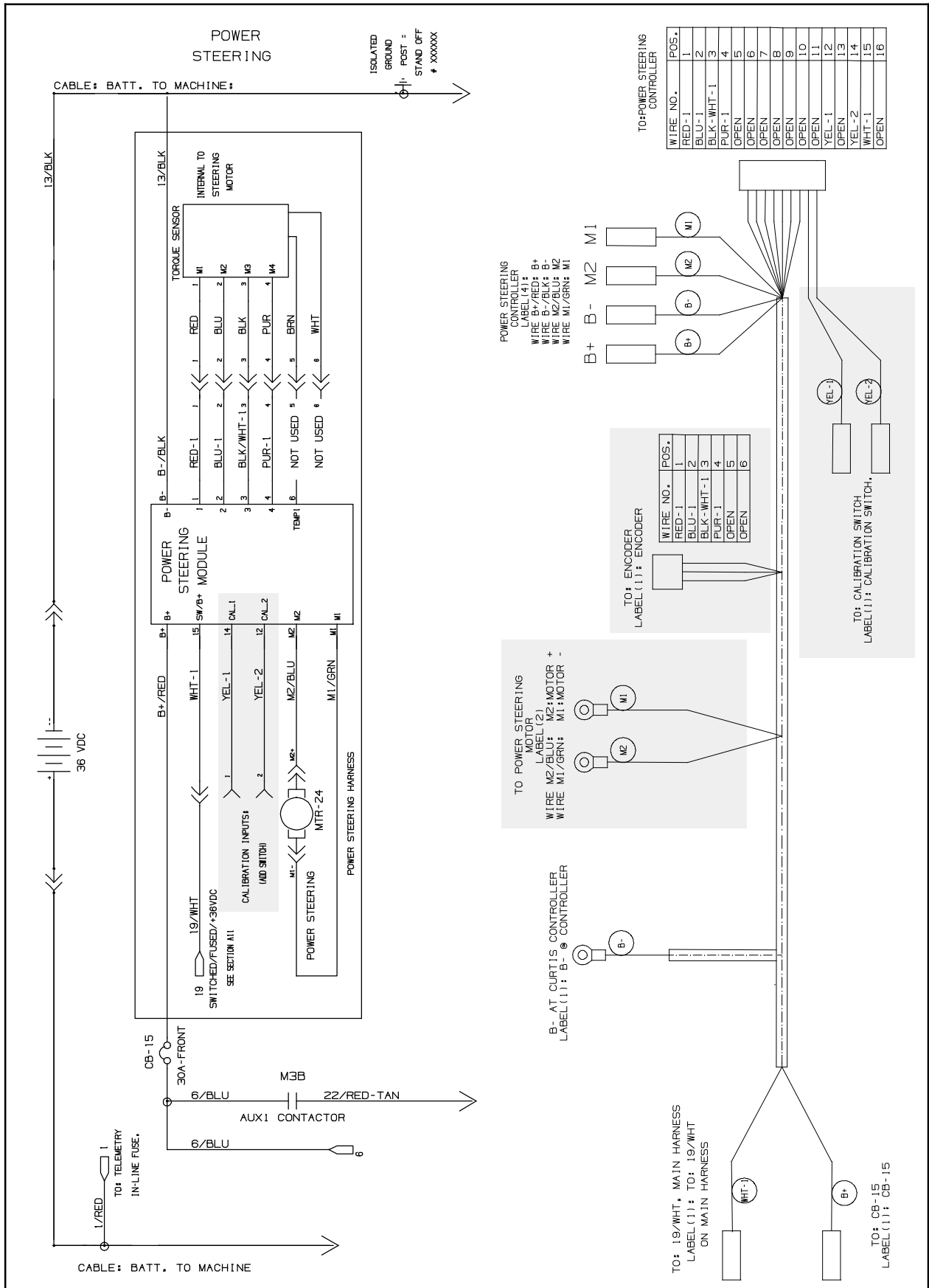
43. Test the machine. Turn the steering wheel in the complete range of motion in both directions. The machine should steer smoothly and with the same amount of resistance in both directions. Recenter the steering wheel and repeat the Calibration Steps if the steering is not functioning smoothly with the same amount of resistance when turned in either direction. Do not turn on any machine functions/options when testing the machine.

*NOTE: All functions and options must remain OFF until after the key is turned to the OFF position to complete calibration.*

44. **Calibration:** Turn the key to the OFF position.

45. **Calibration:** Disconnect the power steering wire harness YEL- 1 wire and YEL- 2 wire from the snap switch (21). (Fig. 26/Fig. 27/ Fig. 29)

46. Reinstall the access panel onto the machine.



**FIG. 29**

**Bill Of Materials For Kit, Field Install, Power Steering - 9018436**

<b>Ref.</b>	<b>Tennant Part No.</b>	<b>Description</b>	<b>Qty.</b>
1	1256311	Bracket Wldt, Mtg, Bearing, Steering	1
2	1057554	Bearing, Flng, 2Hole, 0.75B	2
3	07791	Nut, Hex, Flng, M8 X 1.25	4
4	39349	Washer, Flat, 0.31, SAE	8
5	16931	Screw, Hex, M8 X 1.25 X 20, 8.8	6
6	1239800	Shaft, Steering, Power	1
7	1224699	Sprocket, Steering, 0.75B	1
8	1224893	Screw, Set, M8 X 1.25 X 8, Lock	2
9	00911	Key, Sq, 0.19 X 0.19, 0.75L	1
10	1255953	Sleeve, Spacer, Sprocket, 19.0mm	1
11	1248121	Sleeve, Sprocket Spacer, 6.35	1
12	32491	Washer, Flat, 0.31, STD	5
13	08709	Nut, Hex, Lock, M8 X 1.25, NL	6
14	1020341	Screw, Hex, M8 X 1.25 X 20, SS, SEMS	3
15	1073181	Chain, Rlr, 35 X 41 Pitches	1
16	14799	Link, Chain, Rlr, 35	2
17	1249795	Bracket, Shaft Bearing, Steering	1
18	1244815	Motor, Steering, 36V	1
19	06927	Screw, Pan, Phl, M4 X 0.70 X 16, 4.8	2
20	32483	Washer, Flat, 0.25, SAE	2
21	1008142	Switch, Snap, 25A SPDT	1
22	1241708	Controller, Steering, 36V	1
23	223065	Bearing, Flng, 2Hole, 0.75B [Nyl]	1
24	222505	Screw, Hex, M8 X 1.25 X 45, SS	1
25	386973	Cap, Vyl, .23ID .750L, Blk	1

TENNANT COMPANY  
P. O. Box 1452  
Minneapolis, MN 55440-1452